

WIRING INSTRUCTIONS

TITLE

CIRCULAR SAW with TILT-LOK® HANDLE

BULLETIN

MILWAUKEE ELECTRIC TOOL CORP. 13135 WEST LISBON RD. BROOKFIELD, WIS.

DATE
July 2007

58-01-1321

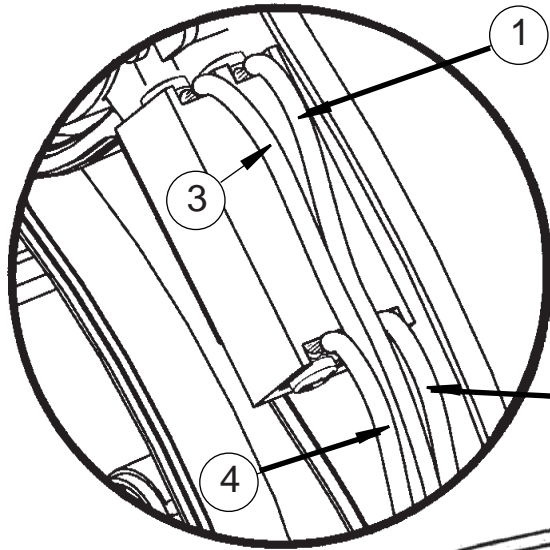

White lead wires #1 and #3 are to be routed to the top of the switch. Position of #1 and #3 are interchangeable.

Black lead wires #2 and #4 are to be routed to the bottom of the switch. Position of #2 and #4 are interchangeable.

Crimp faces must face away from switch.

Bend leads at 90°, making sure not to break wire strands. Ensure all terminals are secure by applying light finger pressure. Route white leads through black leads at switch area as shown.

Lead wire assemblies #3 and #4 may be routed in any order and through either trap.

Lead wire assemblies #3 and #4 are interchangeable.

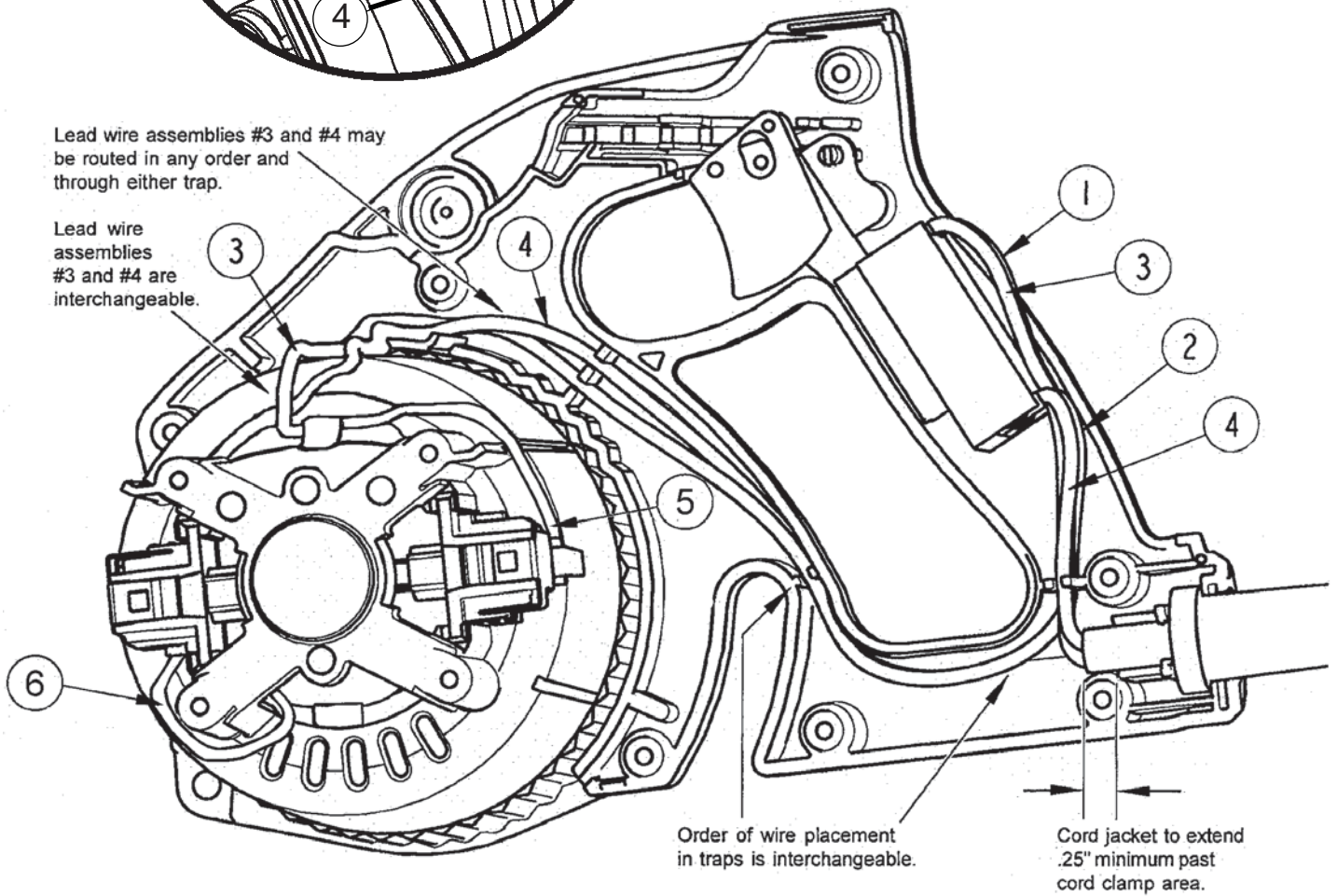

WIRING SPECIFICATIONS

Wire No.	Wire Color	Origin or Part No.	Gauge	Length	Terminals, Connectors and End Wire Preparation
1	White	Cord	14	5.50	Strip .125 for T1.
2	Black	Cord	14	3.75	Strip .125 for T1.
3	White	Field	14		
4	Black	Field	14		
5	White	Field	14		
6	Red	Field	14		

NOTE:

All lead lengths are before stripping. All leads must be held to $\pm .125"$ unless specified elsewhere. Strip wire per ES 13-11. Crimp terminals per ES 13-15.

TERMINAL DESCRIPTION		
Code	Part No.	Qty.
T1	23-74-0120	2