



# SERVICE PARTS LIST

**BULLETIN NO.**  
**54-44-0553**

SPECIFY CATALOG NO. AND SERIAL NO. WHEN ORDERING PARTS		REVISED BULLETIN 54-44-0552	DATE Oct. 2019
<b>18 GAUGE SHEAR</b>			
CATALOG NO. <b>6852-20</b>	SERIAL NUMBER PREFIX & BREAK	<b>A80D</b>	
		WIRING INSTRUCTION <b>See Pages 3 &amp; 4</b>	

**EXAMPLE:**  
Component Parts (Small #)  
Are Included When Ordering  
The Assembly (Large #).

**\*IMPORTANT NOTE\***  
If replacing a Motor Housing in a  
tool with a serial number in the  
range of A80DD1442 1105 to 1776,  
Motor Housing  
31-50-0526 and  
Bearing Cup  
43-86-0125 must  
be ordered and  
installed together.

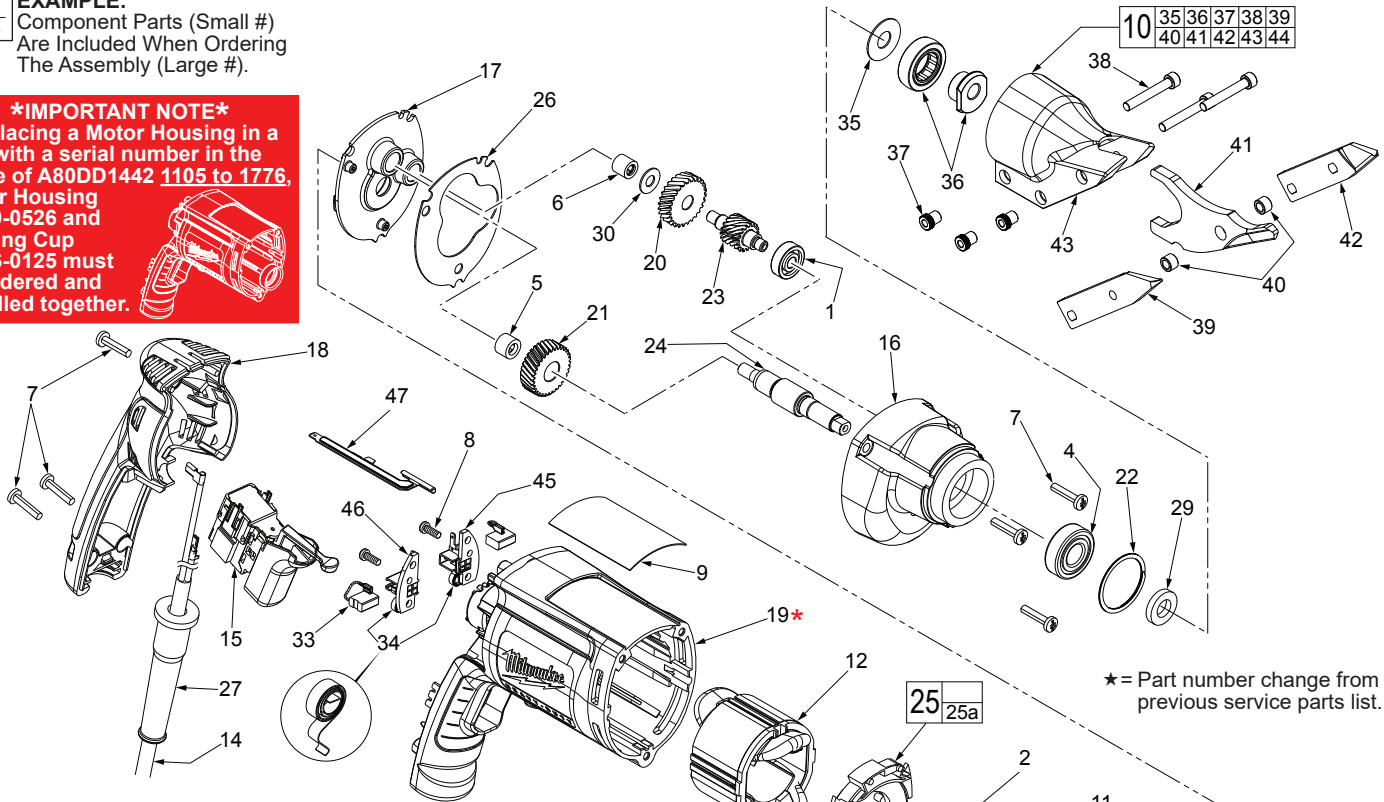
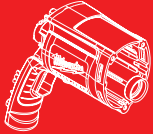

★ = Part number change from  
previous service parts list.

FIG.	PART NO.	DESCRIPTION OF PART	NO. REQ.
1	02-04-0640	Ball Bearing	(1)
2	02-04-0645	Ball Bearing	(1)
3	02-04-0852	Ball Bearing	(1)
4	02-04-1020	Ball Bearing	(1)
5	02-50-1611	Needle Bearing	(1)
6	02-50-2400	Needle Bearing	(1)
7	06-82-7275	7-18 x .75 Slotted Plastite T-20	(6)
★ 8	06-88-1610	M3.5 x 10 Pan Hd. Plastite Screw	(2)
9	12-99-2665	Service Nameplate	(1)
10	48-08-0500	Shear Head Assy. (Includes 35 thru 44)	(1)
11	16-10-2210	Armature Assembly	(1)
★ 12	18-07-7220	Field	(1)
14	22-64-6510	Cord Set	(1)
15	23-66-2625	Defond Switch (See wiring on page 2)	(1)
15a	23-66-2587	Marquardt Switch (See wiring on page 3)	(1)
16	28-14-2394	Gearcase	(1)
17	28-28-2320	Diaphragm	(1)
18	31-15-2010	Handle Halve	(1)
★ 19	31-50-3010	Motor Housing (*See Service Note Above)	(1)
20	32-40-0100	Intermediate Gear	(1)
21	32-75-0115	Spindle gear	(1)
22	34-80-1400	Retaining Ring	(1)
23	36-66-0125	Intermediate Pinion	(1)
24	38-50-5754	Spindle	(1)
25	42-14-0450	Baffle Assembly	(1)
25a	45-30-0030	Slug (Not Shown)	(2)
26	43-44-0985	Gasket	(1)
27	44-76-0210	Cord Protector	(1)
29	45-88-0396	Chuck Washer	(1)
30	45-88-7990	Thrust Washer	(1)
33	22-18-1310	Brush Assembly	(2)
34	23-52-1610	Brush Spring	(2)
35	45-88-7310	Washer	(1)
36	43-16-0100	Eccentric Assembly	(1)
37	43-84-0460	Knurled Insert	(3)
38	06-75-2115	10-24 x 1-1/4 Skt. Hd. Cap Screw	(3)
39	48-44-0170	Blade - Right Side	(1)
40	42-40-0520	Bushing	(2)
41	48-44-0150	Blade - Center	(1)
42	48-44-0160	Blade - Left Side	(1)

FIG.	PART NO.	DESCRIPTION OF PART	NO. REQ.
43	43-76-0400	Shear Housing	(1)
44	49-96-0070	5/32 Hex Allen Wrench (Not Shown)	(1)
★ 45	22-20-0090	Left Brush Holder	(1)
★ 46	22-20-0095	Right Brush Holder	(1)
47	44-60-1700	Ground Pin	(1)
★	23-94-0490	White Leadwire Assy. (See pages 2 & 3)	(1)
★	23-94-0495	Red Leadwire Assy. (See pages 2 & 3)	(1)

**FIG. LUBRICATION:**  
16 Place 5 grams (3/16 oz.) of Type "Y" Grease, No. 49-08-5270 on top of the inserted intermediate ball bearing (1) and on the intermediate pinion (23). After inserting the balance of the gear ing mechanism (20, 30, 28 and 21), place 13 grams (1/2 oz.) of "Y" Grease at the armature pinion centerline in the gearcase and fill to the top of the intermediate gear (20). Grease must contact at least 25% of the intermediate gear teeth.

36,40,41 During assembly, use a dab of Type "E" Grease, No. 49-08-4122 to lubricate flats, pivot hole and sides of center blade (41), eccentric assembly (36) and bushing (40).

5,6,17 Before assembly, lightly coat all press fit areas with lightweight spindle oil.

**FIG. NOTES:**  
5,6,17 Needle bearings to be pressed flush to .010 under flush from the end which has the vendors identification.

When servicing **Shear Head Assembly No. 48-08-0500** pay close attention to the placement of the Bushings. One is to be placed in the hole of the Center Blade and is to be held in place with the front most screw on the Shear Housing. The other bushing is to be located below the small concave notch of the Center Blade and is to be secured with the middle screw on the Shear Housing. Prior to assembly, it is recommended to use Type 'E' Grease, No. 49-08-4122 on the following areas: Place a dab of grease in the pivot (bushing) hole and on the bushing notch of the Center Blade. Place a dab of grease on the rear flats of the Center Blade. Coat both bushings completely with grease. Place a liberal amount of grease on the entire Eccentric Assembly.

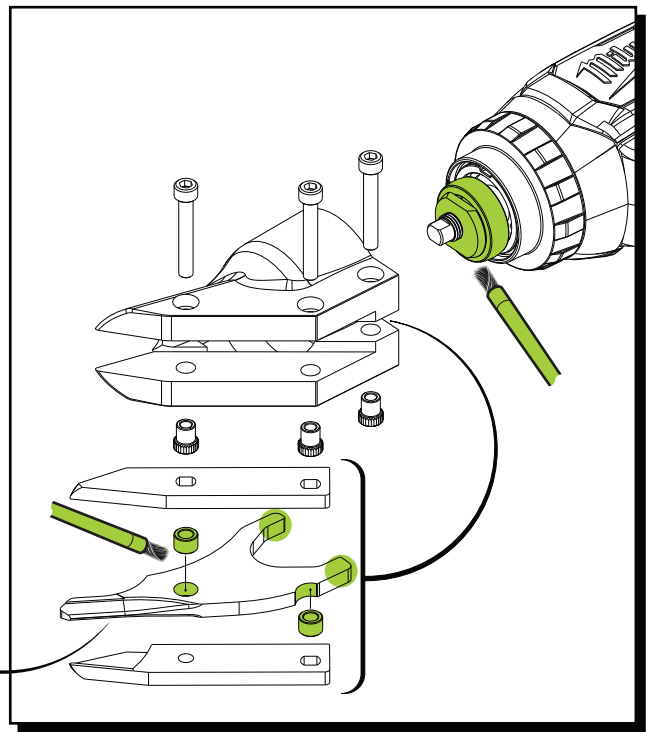
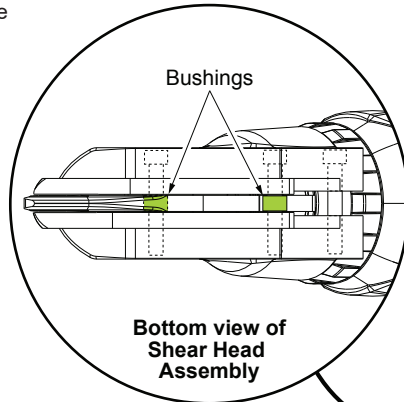

**REMOVING SHEAR HEAD ASSEMBLY FROM TOOL**

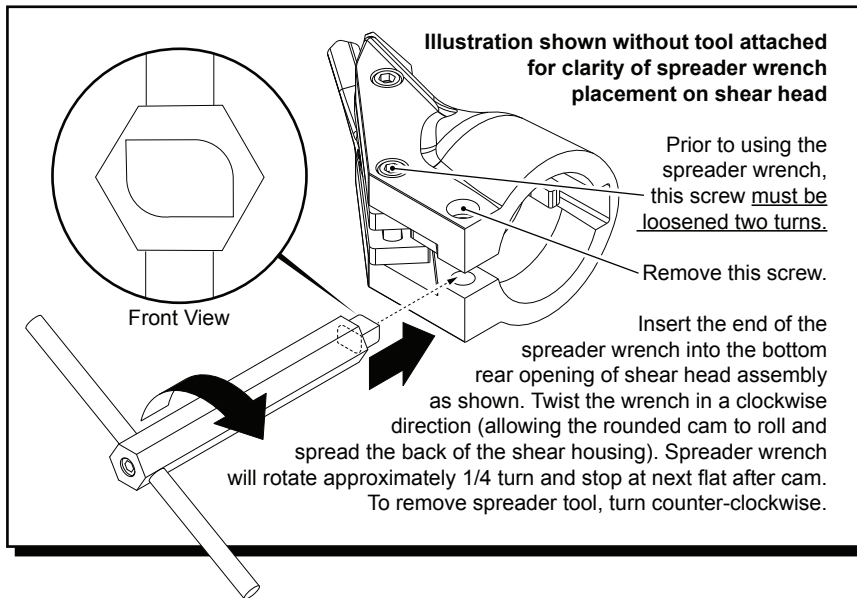

**SERVICE TOOLS:**

**Spreader Wrench No. 61-30-0300**  
for 14 Gauge Shear Head 48-08-0505  
used on Shear No. 2636-20

for 18 Gauge Shear Head 48-08-0507  
used on Shear 2637-20

**Spreader Wrench No. 61-30-0310**  
for 18 Gauge Shear Head 48-08-0500  
used on Shears 2635-20 and 6852-20

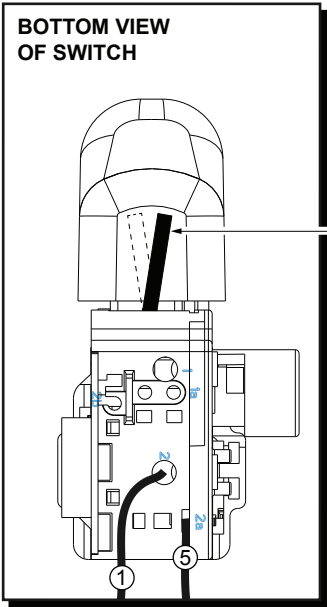

**BOTTOM VIEW OF SWITCH**

**NOTE:**  
Prior to installation, Switch lever must be in the FORWARD position as shown.

**DEFOND SWITCH**

● = WIRE TRAPS or GUIDES

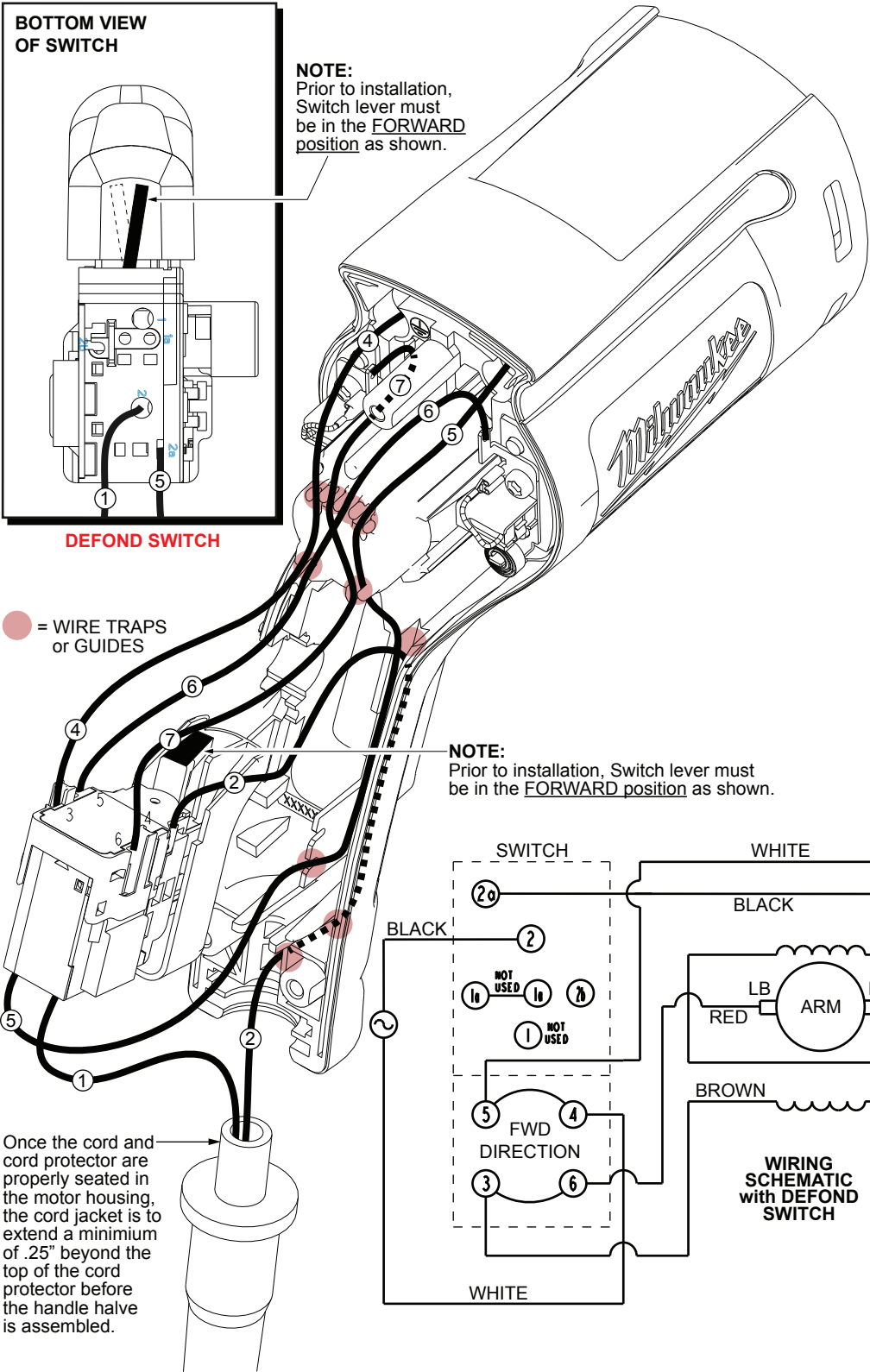

**NOTE:**  
Prior to installation, Switch lever must be in the FORWARD position as shown.

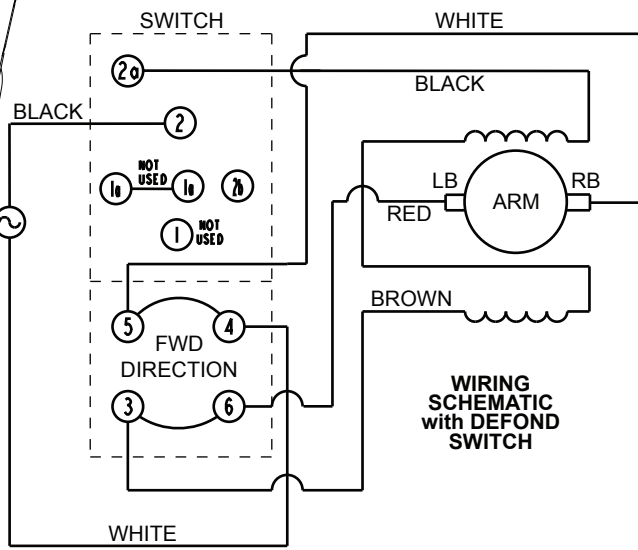
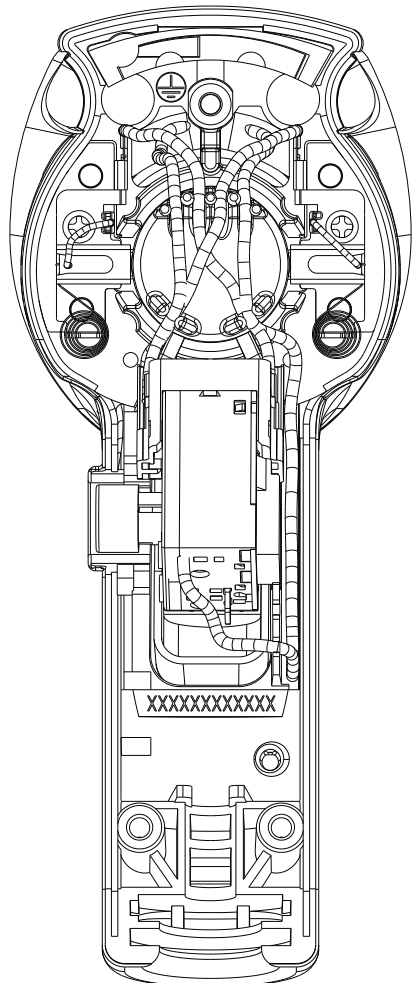

**AS AN AID TO REASSEMBLY, TAKE NOTICE OF WIRE ROUTING AND POSITION IN WIRE GUIDES AND TRAPS WHILE DISMANTLING TOOL.**

**BE CAREFUL AND AVOID PINCHING WIRES BETWEEN HANDLE HALVES WHEN ASSEMBLING.**

Once the cord and cord protector are properly seated in the motor housing, the cord jacket is to extend a minimum of .25" beyond the top of the cord protector before the handle halve is assembled.

**WIRING SPECIFICATIONS**

Wire No.	Wire Color	Origin or Gauge	Length	Terminals, Connectors and 1 or 2 End Wire Preparation
1	Black	*	----	*Component of cord set, pin hsg. assy. or blade hsg. assy. Connect to #2 on switch bottom.
2	White	*	----	*Component of cord set, pin hsg. assy. or blade hsg. assy. Connect to #4 on switch top.
4	Brown	Field	----	Component of field. Connect to #3 on switch top.
5	Black	Field	----	Component of field. Connect to #2a on switch bottom.
6	White	23-94-0490	----	Leadwire assembly. Connect to right brush holder and #5 on switch top.
7	Red	23-94-0495	----	Leadwire assembly. Connect to left brush holder and #6 on switch top.

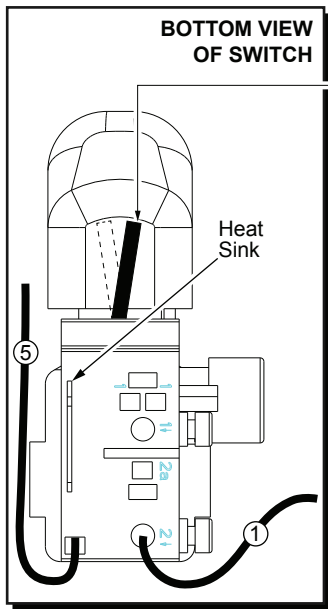

**BOTTOM VIEW OF SWITCH**

**NOTE:**  
Prior to installation, Switch lever must be in the **FORWARD** position as shown.

**MARQUARDT SWITCH**

● = WIRE TRAPS or GUIDES

**NOTE:**  
Prior to installation, Switch lever must be in the **FORWARD** position as shown.

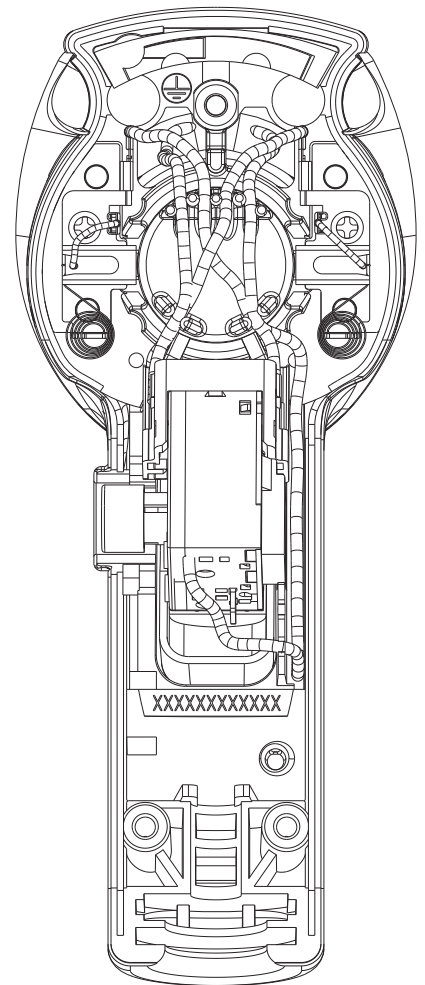

Once the cord and cord protector are properly seated in the motor housing, the cord jacket is to extend a minimum of .25" beyond the top of the cord protector before the handle halve is assembled.

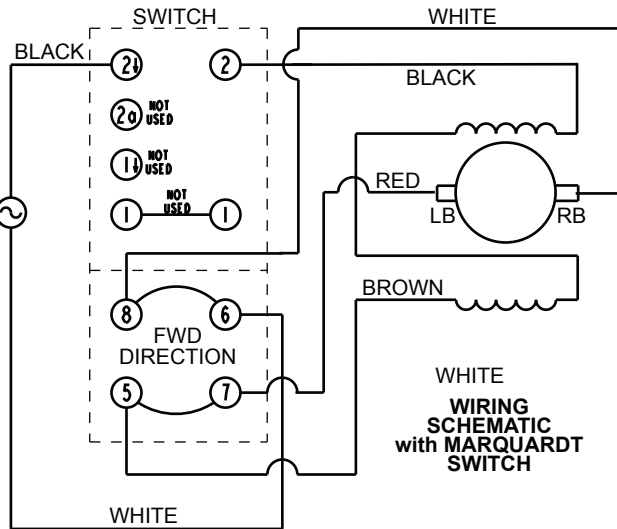

**AS AN AID TO REASSEMBLY, TAKE NOTICE OF WIRE ROUTING AND POSITION IN WIRE GUIDES AND TRAPS WHILE DISMANTLING TOOL.**

**BE CAREFUL AND AVOID PINCHING WIRES BETWEEN HANDLE HALVES WHEN ASSEMBLING.**

**WHITE WIRING SCHEMATIC with MARQUARDT SWITCH**

**WIRING SPECIFICATIONS**

Wire No.	Wire Color	Origin or Gauge	Length	Terminals, Connectors and 1 or 2 End Wire Preparation
1	Black	*	----	*Component of cord set, pin hsg. assy. or blade hsg. assy. Connect to #2↓ on switch bottom.
2	White	*	----	*Component of cord set, pin hsg. assy. or blade hsg. assy. Connect to #6 on switch top.
4	Brown	Field	----	Component of field. Connect to #5 on switch top.
5	Black	Field	----	Component of field. Connect to #2 on switch bottom.
6	White	23-94-0490	----	Leadwire assembly. Connect to right brush holder and #8 on switch top.
7	Red	23-94-0495	----	Leadwire assembly. Connect to left brush holder and #7 on switch top.