



Smith-Blair
a xylem brand

SPECIFICATION

OMNI™ CAST COUPLING – STD SLEEVE

MODEL 441

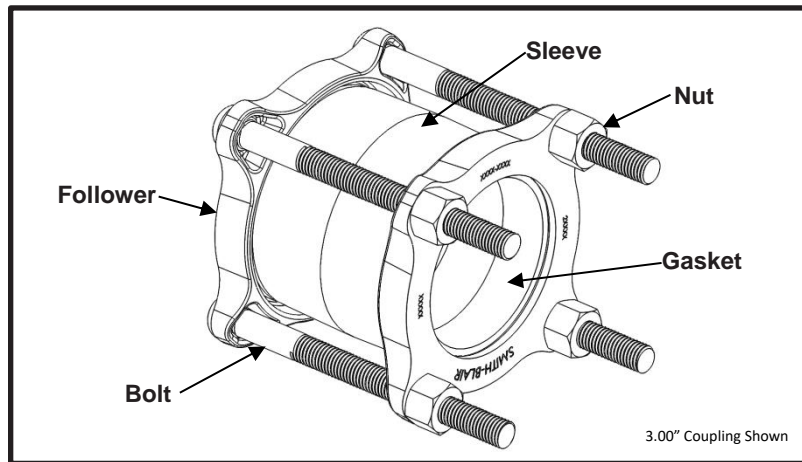

APPLICATIONS

- **Typical Uses**
 - Joining plain-end pipe of same outside diameters
 - Joining plain-end pipe of different outside diameters with same nominal size
 - Replace split or excessively damaged pipe
- **Standard Pipe Sizes**
 - 2" to 16" nominal
- **Type of Pipe**
 - Carbon Steel, Stainless Steel, Ductile Iron, Asbestos Cement, PVC, HDPE (*with stiffeners*)
- **Working Pressure**
 - 250 psi

MATERIALS

- **Follower**
 - Cast using Ductile Iron 65-45-12 per ASTM A536
 - Flexi-Coat® fusion bonded epoxy finish
- **Sleeve**
 - Cast using Ductile Iron 65-45-12 per ASTM A536
 - Flexi-Coat® fusion bonded epoxy finish
 - Designed to provide up to 2.40" of range with a single assembly
- **Gasket**
 - Nitrile (Buna-N) per ASTM D2000
 - Compounded to resist water, oil, natural gas, acids, alkalies, most (aliphatic) hydrocarbon fluids, and many other chemicals
 - Temperature range: -20°F to +180°F
- **Bolts**
 - High Strength Low Alloy (HSLA) Steel per AWWA C111/A21.11
 - 5/8"-11UNC, Track Head Oval Neck with Rolled Threads
- **Nut**
 - HSLA Steel per AWWA C111/A21.11
 - 5/8"-11UNC, Heavy Hex Semi-Finished

LISTINGS



Smith-Blair
a xylem brand

SPECIFICATION

OMNI™ CAST COUPLING – STD SLEEVE

MODEL 441

- Certified to NSF/ANSI 61 and NSF/ANSI 372
- Meets applicable portions of AWWA C219
- Flexi-Coat® Fusion-Bonded Epoxy Coating meets requirements of AWWA C213

OPTIONS

- Type 304 Stainless Steel hardware with fluoropolymer coated nuts to prevent galling
- Type 316 Stainless Steel hardware with fluoropolymer coated nuts to prevent galling
- Alternative gasket material (e.g. Viton, EPDM, etc.)
- Insulating boot

NOTES

- Pipe stiffeners **are required** when this product is used on HDPE
- Xylem, Smith-Blair, SB stylized, and Flexi-Coat are registered trademarks and Omni is a trademark of Xylem, Inc., or one of its subsidiaries.
- These product specifications were correct at the time of publication and are subject to change without notice
- See the Smith-Blair website for part numbers and ordering information
- See the Smith-Blair website for warranty information
- See the Smith-Blair website for corrosion notice



THIS PRODUCT DOES NOT RESTRAIN PIPE MOVEMENT. Proper anchoring is required to prevent pipe pull out. Failure to anchor or improper anchoring can result in dangerous pipe content escape, property damage, serious injury, or death. Refer to smith-blair.com for products designed to restrain axial pipe movement. Read the product installation instructions prior to installing this product.



Smith-Blair
a xylem brand

SPECIFICATION

OMNI™ CAST COUPLING – STD SLEEVE

MODEL 441

Recommended Pipe to Pipe Centerline Gaps

Sleeve Length	Optimum Gaps		Maximum Gap
	Straight Run	Deflected Joints	
5"	1/2"	1"	2"
7"	1/2"	1-1/2"	3"
10"	1"	2-1/4"	4-1/2"
Longer Than 10"	1"	2-3/4"	"Sleeve Length" – 6"

Pipe gap to be centered in coupling sleeve.

Total Maximum Allowable Axial Pipe Movement per Coupling

Coupling Size	Allowable Movement
3/4" to 2"	1/8"
2-1/2" to 10"	1/4"
10-3/4" and Larger	3/8"

Pipe End Tolerances

Nominal Pipe Size	Minus Tolerance	Plus Tolerance
1/2" up to 16"	-0.06	+0.06

Maximum Angular Deflection per Coupling 4° (Pipe-to-Pipe) 2° (Pipe-to-Sleeve)

30 Globe Ave, Texarkana, AR 71854
Ph: 870-773-5127 • Fax: 870-773-5212
Toll-Free Numbers: Ph: 800-643-9705 • Fax: 800-648-6792

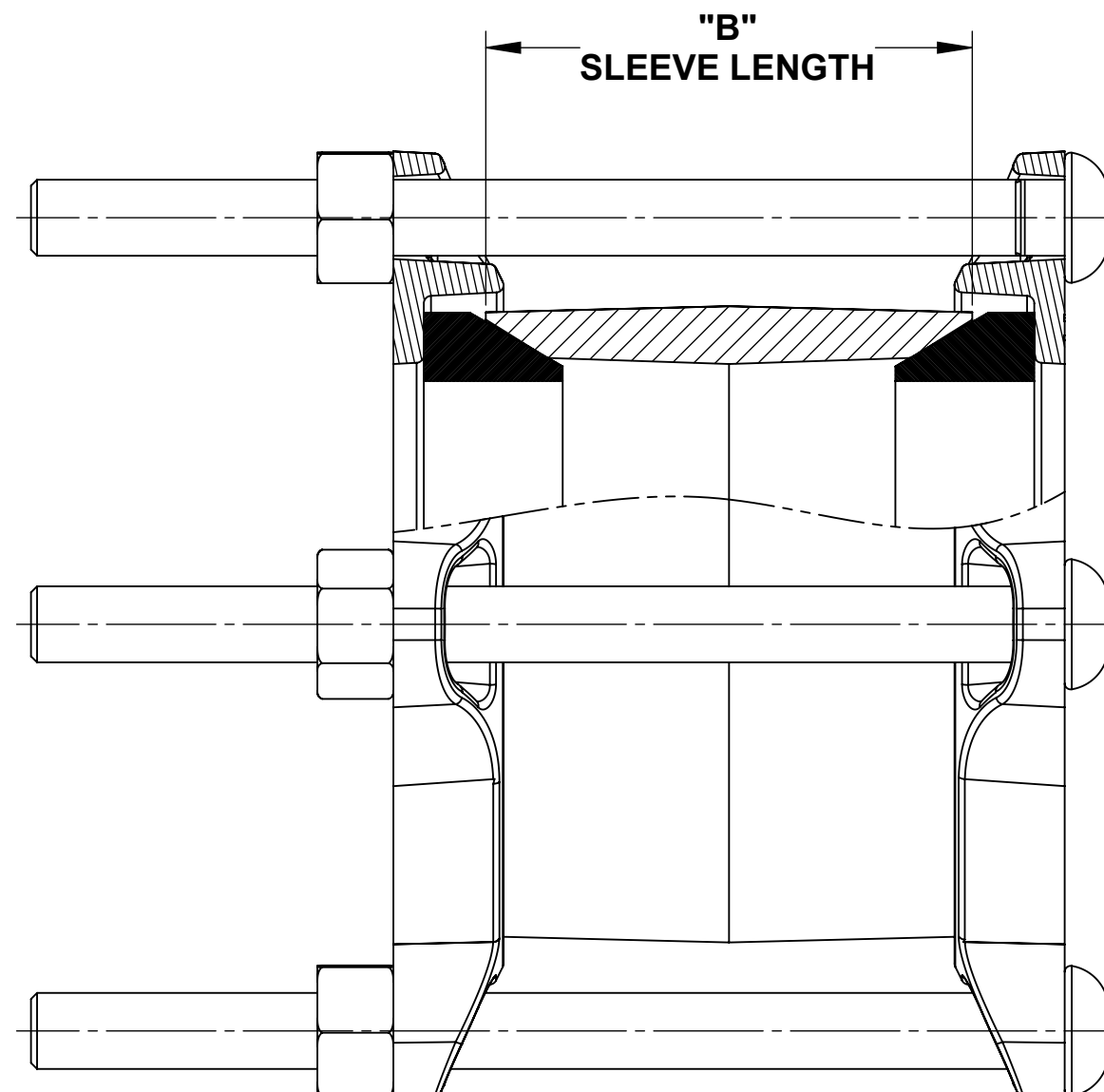
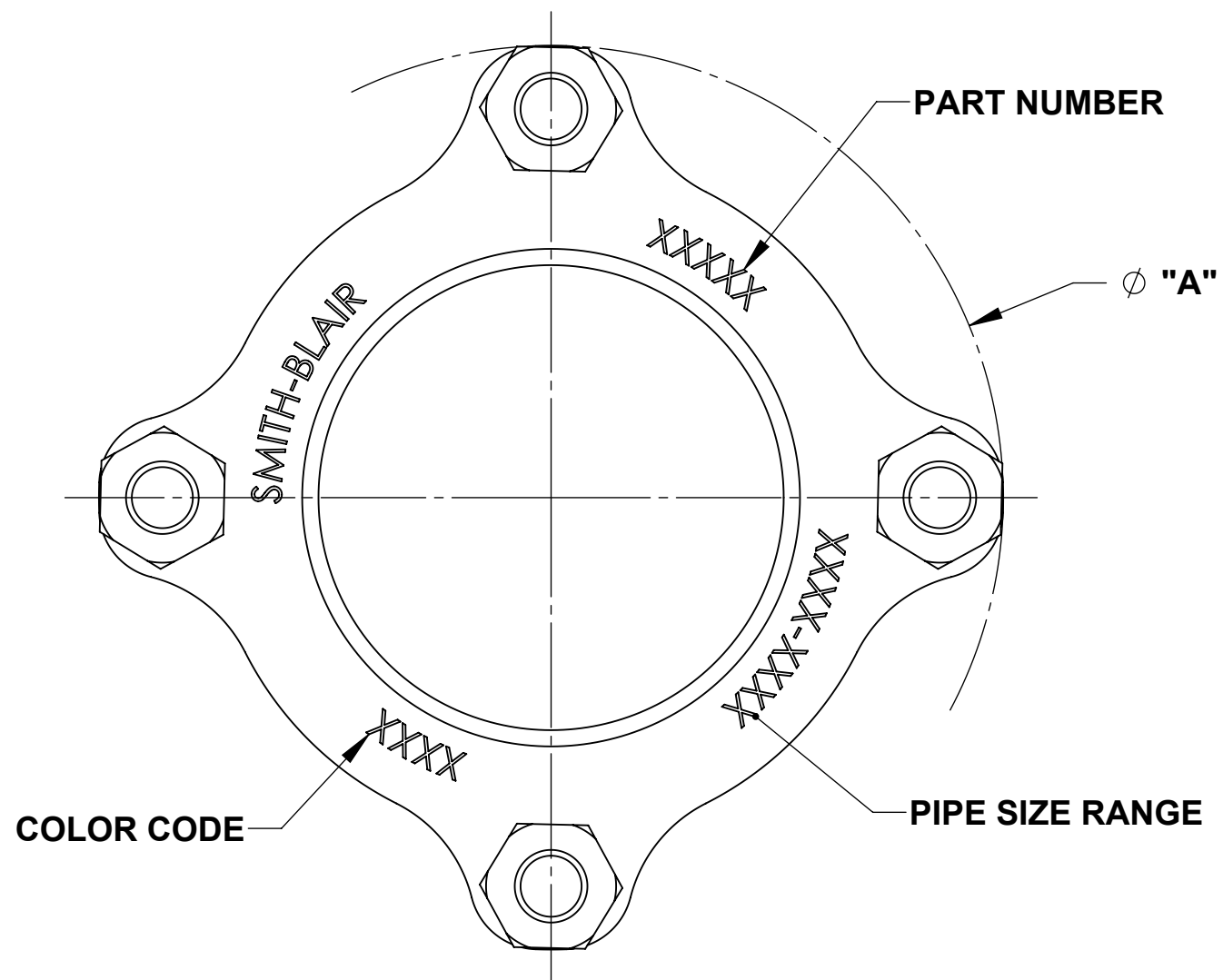

- NOTES:**
 1. SEE SMITH-BLAIR CATALOG FOR PIPE RANGE AVAILABILITY
 2. 6" COUPLING SHOWN OTHER SIZES SIMILAR

NOM. PIPE SIZE	PIPE O.D. RANGE	A	B	HARDWARE		APPROX WEIGHT (LBS)
				QTY.	SIZE	
2	2.34 TO 2.63	6.01	4.00	2	5/8" X 8.00"	9
2.50	2.65 TO 2.88	6.52	4.00	2	5/8" X 8.00"	9
3	2.85 TO 4.14	7.78	4.00	4	5/8" X 8.00"	14
4	4.00 TO 5.45	9.01	5.00	5	5/8" X 8.00"	15
6	6.00 TO 7.65	11.28	5.00	5	5/8" X 8.00"	25
8	8.00 TO 9.85	13.48	5.00	5	5/8" X 9.00"	31
10	10.00 TO 12.20	15.83	6.00	6	5/8" X 10.50"	47
12	12.00 TO 14.40	18.30	6.00	8	5/8" X 10.50"	52
14	15.30 TO 16.90	20.55	6.00	8	5/8" X 9.00"	59
16	17.40 TO 19.20	22.93	6.00	10	5/8" X 10.50"	71

WRENCH SIZE CHART	
NUT	SIZE
5/8"-11UNC HH	1-1/16"

TOLERANCES U.N.O. .XX= ±.03 .XXX= ±.015 FRACTIONS= ±1° ANGLES= ±1° MACH. FIN=	NOTES: REMOVE BURRS AND SHARP EDGES DO NOT SCALE DWG.	APP'D	DATE
	SCALE: N/A	CK'D	DATE
ALL DIMENSIONS ARE IN INCHES.	DRN	CHD	DATE 1/13/16
TITLE SPECIFICATION OMNI™ CAST COUPLING - STD SLEEVE MODEL 441			
SMITH-BLAIR, Inc. TEXARKANA, ARKANSAS		P/N N/A	
DWG. NO. SPEC_441.DRW		1 OF 1 SHEET	10/5/16 REV.