

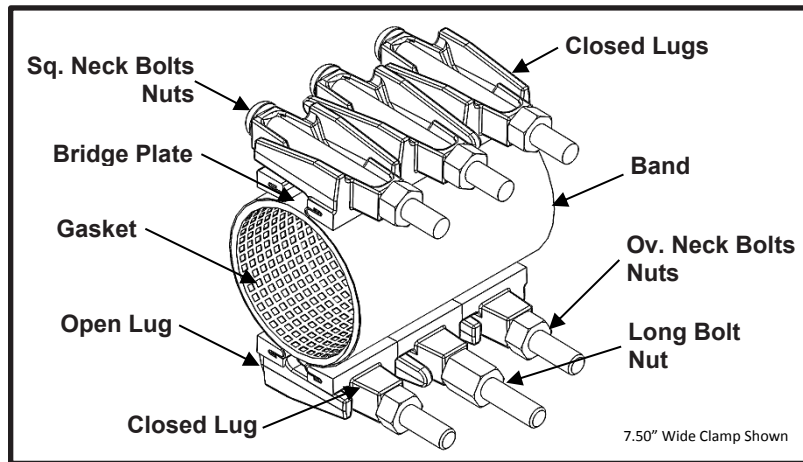

Smith-Blair
a xylem brand

SPECIFICATION FULL CIRCLE® REPAIR CLAMP MODEL 227



APPLICATIONS

Typical Uses

- Repair leaks due to complete breaks, splits, or holes
- Joining pipes of the same diameter
- Examples:

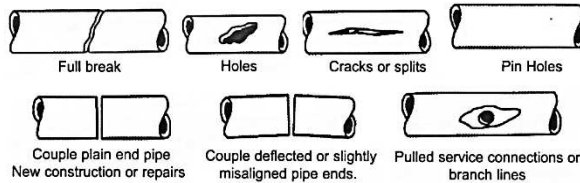

Standard Pipe Sizes

- 3" to 12" nominal

Standard Widths

- 7.5", 10.0", 12.5", 15.0", 20.0", 25.0", 30.0"

Type of Pipe

- Carbon Steel, Stainless Steel, Ductile Iron, PVC, HDPE DR17 or thicker (with use of spring washers), Asbestos Cement, Copper, Aluminum

Working Pressure

- Up to 175 psi depending on pipe size, type of pipe, type of repair, pipe diameter, service conditions, and installation workmanship

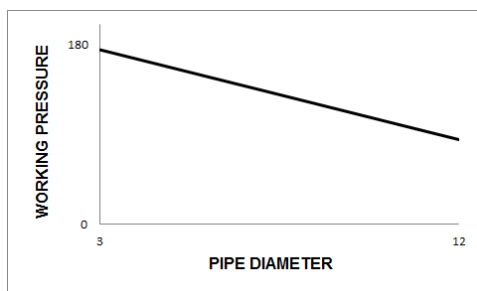



Smith-Blair
a xylem brand

SPECIFICATION

FULL CIRCLE[®] REPAIR CLAMP

MODEL 227

MATERIALS

- **Band**
 - Type 304 Stainless Steel per ASTM A240
 - Band Thickness: 20 gauge thick for clamps 6.90" diameter and smaller
19 gauge thick for clamps 8.63" diameter and larger
 - Hemmed ends for lug removal in tight applications
- **Lugs**
 - Cast using Ductile Iron 80-55-06 per ASTM A536
 - Flexi-Coat[®] fusion bonded epoxy finish
 - Slot cast in lug to capture band hem
 - Designed for drop in replaceable bolts
 - One open loop lug and one closed loop lug. The bolts do not have to be removed to install clamp, preventing lost hardware
 - Remaining opening(s) have closed-closed loop lugs securing clamp sections together for ease of installation
 - Long interlocking fingers allow for up to 0.80 inches of range (0.40 inches per side) in clamp
 - Interchangeable lugs allow combining smaller diameter clamps to create larger diameter clamps
 - Mutually supporting sliding fingers
- **Gasket**
 - Nitrile (Buna-N) per ASTM D2000
 - Gasket Thickness: 0.192 thickness for clamps 3.50" diameter and smaller
0.250 thickness for clamps 4.50" diameter and larger
 - Compounded to resist water, oil, natural gas, acids, alkalies, most (aliphatic) hydrocarbon fluids, and many other chemicals
 - Temperature range: -20°F to +180°F
 - Full 360° gridded face gasket
 - Tapered ends allow for full circumferential sealing
- **Bridge Plate**
 - Type 304 Stainless Steel quarter-hard per ASTM A240
 - Molded and recessed into gasket
 - Preformed for uniform distribution of gasket pressure over the entire pipe circumference
- **Bolts**
 - High Strength Low Alloy (HSLA) Steel per AWWA C111/A21.11
 - Size(s): 5/8"-11UNC x 6.00" long, Track Head Oval Neck (closed lug to open lug)
5/8"-11UNC x 6.88" long, Track Head Square Neck (closed lug to closed lug)
 - Fe/Zn coated per ASTM F1941-10
 - Rolled threads
 - Drop in replaceable bolts
- **Long Bolt**
 - HSLA Steel per AWWA C111/A21.11
 - 5/8"-11UNC x 6.88" long, Track Head Oval Neck (closed lug to open lug)
 - Fe/Zn coated per ASTM F1941-10
 - Rolled threads
 - Used on clamps 4.50" diameter and smaller to facilitate the initial clamp installation
 - Drop in replaceable bolts



Smith-Blair
a xylem brand

SPECIFICATION

FULL CIRCLE® REPAIR CLAMP

MODEL 227

- **Nuts**
 - HSLA Steel per AWWA C111/A21.11
 - 5/8"-11UNC, Heavy Hex Semi-Finished
 - Fe/Zn coated per ASTM F1941-10
- **Long Nut**
 - HSLA Steel per AWWA C111/A21.11
 - 5/8"-11UNC x 1.00" long, Heavy Hex Semi-Finished
 - Fe/Zn coated per ASTM F1941-10
 - Used to provide hand tightening during initial clamp installation

LISTINGS/STANDARDS

- Certified to NSF/ANSI 61 and NSF/ANSI 372
- Flexi-Coat® Fusion-Bonded Epoxy Coating meets requirements of AWWA C213
- Meets applicable portions of AWWA C230

OPTIONS

- Type 316 Stainless Steel band
- Type 304 Stainless Steel hardware with fluoropolymer coated nuts to prevent galling
- Type 316 Stainless Steel hardware with fluoropolymer coated nuts to prevent galling
- Alternative gasket material (e.g. Viton, EPDM, etc.)
- Spring washers for use of clamp on HDPE pipe
- Offset gaskets to allow for repairing longer cracks using multiple clamps
- Conductivity feature

NOTES

- Spring washers **are required** when this product is used on DR17 or thicker HDPE pipe (Not recommended for use on HDPE pipe DR 17 or thinner)
- Pipe stiffeners **are required** when this product is used to join HDPE and thin wall PVC pipe
- Xylem, Smith-Blair, SB stylized, Flexi-Coat, and Full Circle are registered trademarks of Xylem, Inc., or one of its subsidiaries
- These product specifications were correct at the time of publication and are subject to change without notice
- See the Smith-Blair website for part numbers and ordering information
- See the Smith-Blair website for warranty information
- See the Smith-Blair website for corrosion notice



WARNING THIS PRODUCT DOES NOT RESTRAIN PIPE MOVEMENT. Proper anchoring is required to prevent pipe pullout. Failure to anchor or improper anchoring can result in dangerous pipe content escape, property damage, serious injury, or death. Read the product installation instructions prior to installing this product.

30 Globe Ave, Texarkana, AR 71854
Ph: 870-773-5127 • Fax: 870-773-5212
Toll-Free Numbers: Ph: 800-643-9705 • Fax: 800-648-6792

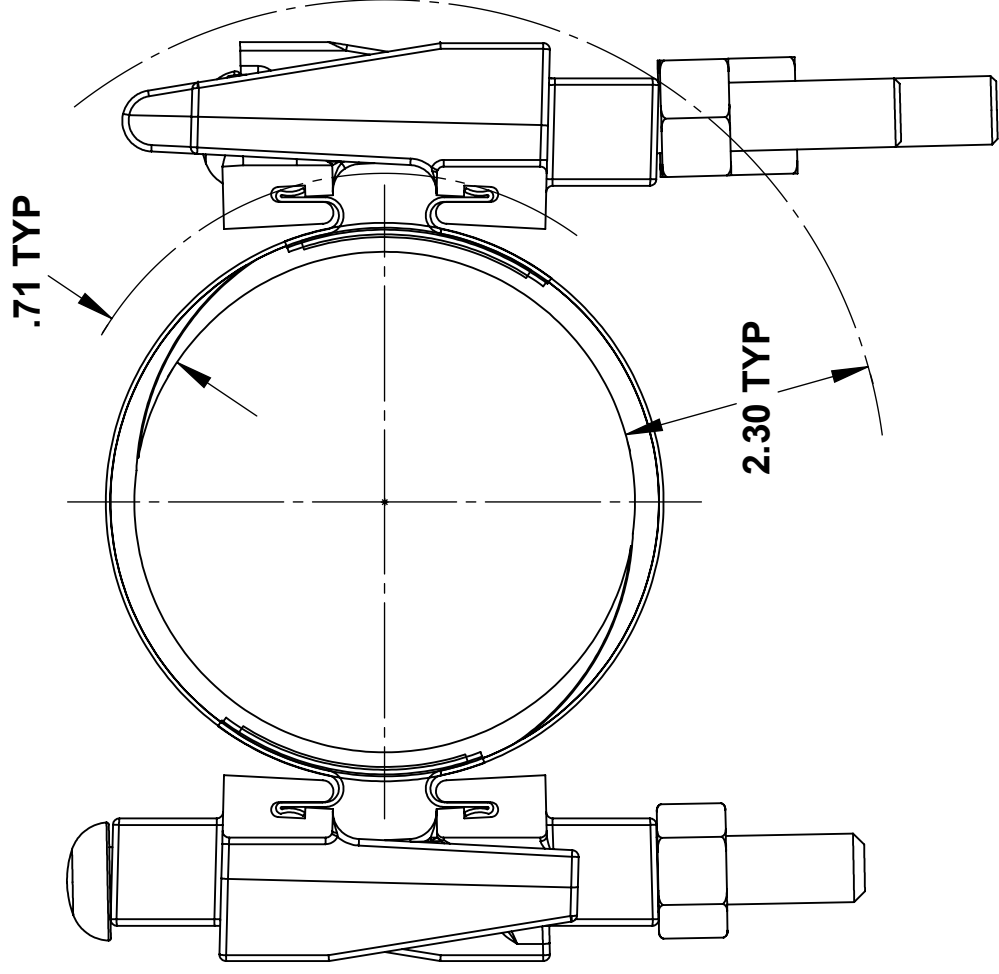
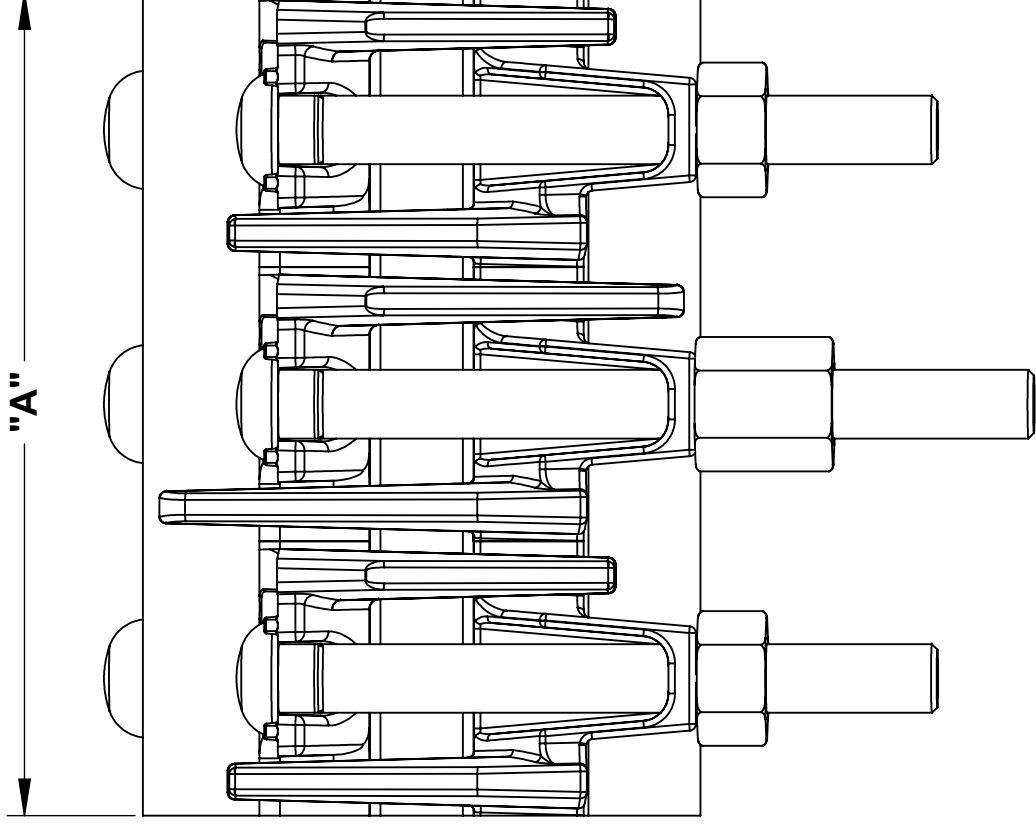

- NOTES:**
1. LONG OVAL NECK BOLTS ONLY PROVIDED ON CLAMPS 4.50" DIAMETER AND SMALLER
 2. SEE SMITH-BLAIR CATALOG FOR AVAILABLE PIPE DIAMETER AND WIDTH COMBINATIONS AS SOME COMBINATIONS ARE NOT AVAILABLE
 3. 7.50" WIDE CLAMP SHOWN OTHER SIZES SIMILAR.

A	BOLT QUANTITY				TOTAL	LONG NUT QUANTITY	SOCKET SIZE
	OVAL NECK		SQUARE NECK				
	SHORT	LONG					
7.50	2	1	3	6	1	1-1/16"	
10.00	2	2	4	8	2		
12.50	3	2	5	10	2		
15.00	4	2	6	12	2		
20.00	5	3	8	16	3		
30.00	8	4	12	24	4		

TOLERANCES U.N.O.
 XX= ±.03
 XXX= ±.015
 FRACTIONS=
 ANGLES=±1°
 MACH. FIN=
 ALL DIMENSIONS
 ARE IN INCHES.

NOTES:
 REMOVE BURRS
 AND SHARP EDGES
 DO NOT SCALE DWG.

SCALE: N/A
 APP'D
 CK'D
 DRN
 CHD
 DATE
 DATE
 DATE

TITLE
SPECIFICATION
FULL CIRCLE® REPAIR CLAMP
MODEL 227

P/N
SMITH-BLAIR, Inc.
 TEXARKANA, ARKANSAS

N/A

DWG. NO. **SPEC_227.DRW**
 1 OF 1 SHEET
 1/16/19 REV.